

## CNC3310 – 2M POE IR IP Dome Camera



### Features

- 2 Megapixel 1920x1080 @25fps
- H.264 High Profile
- ONVIF compatible
- 3.6mm Fixed Lens
- 3D-DNR, DWDR etc
- 3 ROI
- 3-Stream
- Day&Night by Filter Change
- 2nos LED Array, 0 Lux up to 15m
- Network 10/100 Base-T
- Aluminum Casing with Epoxy
- IP66
- POE / 12VC Dual Power

### SPECIFICATION

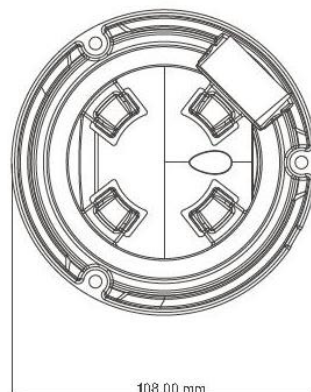
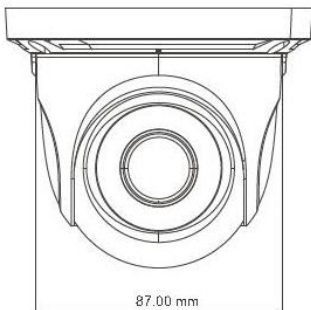

Model	CNC3310
Image Sensor	1/2.8" progressive scan CMOS Sensor
Resolution	1920x1080 @25fps (PAL)
Shuttle	1/25s ~ 1/100,000s
Lens	M12 3.6mm Fixed Lens
LEDs	2nos 850nm IR LED Array
Day & Night	Filter Change or TDN (True Day & Night)
Min. Illumination	0 Lux up to 15m
Network	10/100-BaseT, RJ45
Bit Rate	256Kbps ~ 5Mbps
Compression	3-Stream : H.264 High Profile / MJPEG
Working Environment	-20° ~+50°C, <90° Humidity (Non-Condensing)
Power	POE IEEE 802.3af compliant/12VDC, Max. 4W
Dimension	87mm(φ) x 108mm(H), 370g

\* Specification maybe changed without prior notice